

VT7DB or VT7DBS - B42 - B10 - 1 R 00 - A 1 00 -

**VT7DB** series-ISO 2 bolts 3019-2  
mounting flange 125 A2 HW  
**VT7DBS** series- SAE C 2 bolts  
Mounting flange J744c

**Cam ring for "P1"**

Volumetric displacement cm<sup>3</sup>/rev (in<sup>3</sup>/rev)

B14 = 43.9 (2.68)	B31 = 99.1 (6.05)
B17 = 55.0 (3.36)	B35 = 113.4 (6.92)
B20 = 66.0 (4.03)	B38 = 120.6 (7.36)
B22 = 70.3 (4.29)	B42 = 137.5 (8.39)
B24 = 81.1 (4.95)	045 = 145.7 (8.89)
B28 = 89.9 (5.49)	050 = 157.9 (9.64)

**Cam ring for "P2"**

Volumetric displacement cm<sup>3</sup>/rev (in<sup>3</sup>/rev)

B02 = 5.7 (0.35)	B09 = 28.0 (1.71)
B03 = 9.8 (0.60)	B10 = 31.8 (1.94)
B04 = 12.8 (0.78)	B11 = 34.9 (2.13)
B05 = 15.9 (0.97)	B12 = 40.9 (2.50)
B06 = 19.8 (1.21)	B14 = 45.1 (2.75)
B07 = 22.5 (1.37)	B15 = 50.0 (3.05)
B08 = 24.9 (1.52)	

**Modifications**

**Mounting W/connection variables**

	UNC VT7DBS		METRIC VT7DB-VT7DBS	
	00	01	M0	M1
P2	1"	3/4"	1"	3/4"

**Seal class**

- 1 - S1 (for mineral oil)
- 4 - S4 (for fire resistant fluids)
- 5 - S5 (for mineral oil and fire resistant fluids)

**Design letter**

**Porting combination** (see page BM-1-5)  
00 - standard

**Direction of rotation  
(view on shaft end)**

- R - clockwise
- L - counter-clockwise

**Type of shaft VT7DBS**

- 1 - keyed (SAE C)
- 2 - keyed (no SAE)
- 3 - splined (SAE C)
- 4 - splined (spec. SAE C)

**Type of shaft VT7DB- VT7DBS**

- 5 - keyed (ISO 3019-2-G32M)

**INTERNAL LEAKAGE ( TYPICAL )**

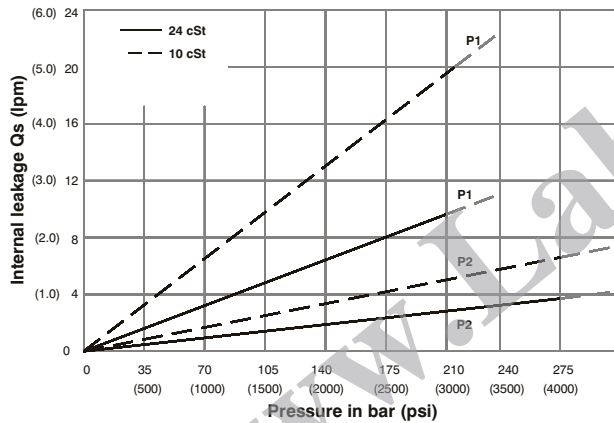

Do not operate pump more than 5 seconds at any speed or viscosity if internal leakage is more than 50% of theoretical flow. Total leakage is the sum of each section loss at its operating conditions.

**NOISE LEVEL ( TYPICAL )**

VT7DB- B31-B10

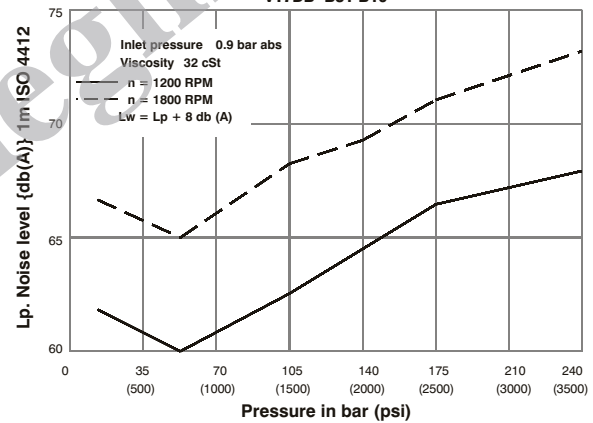

Double pump noise level is given with each section discharging at the pressure noted on the curve.

**HYDROMECHANICAL POWER LOSS ( TYPICAL )**

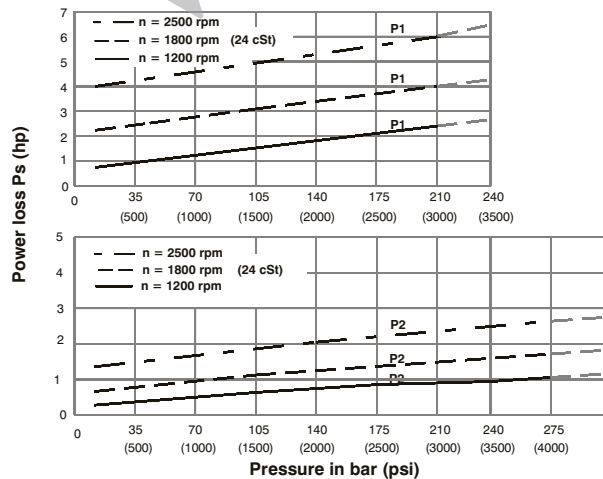

Total hydromechanical power loss is the sum of each section at its operating conditions.

**PERMISSIBLE RADIAL LOAD**

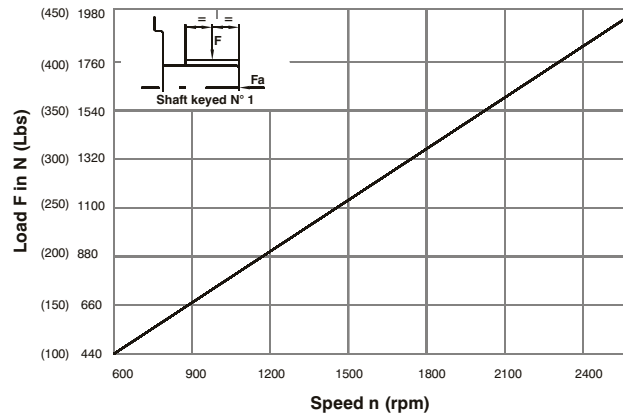

Maximum permissible axial load Fa = 1200 N (270 Lbs)



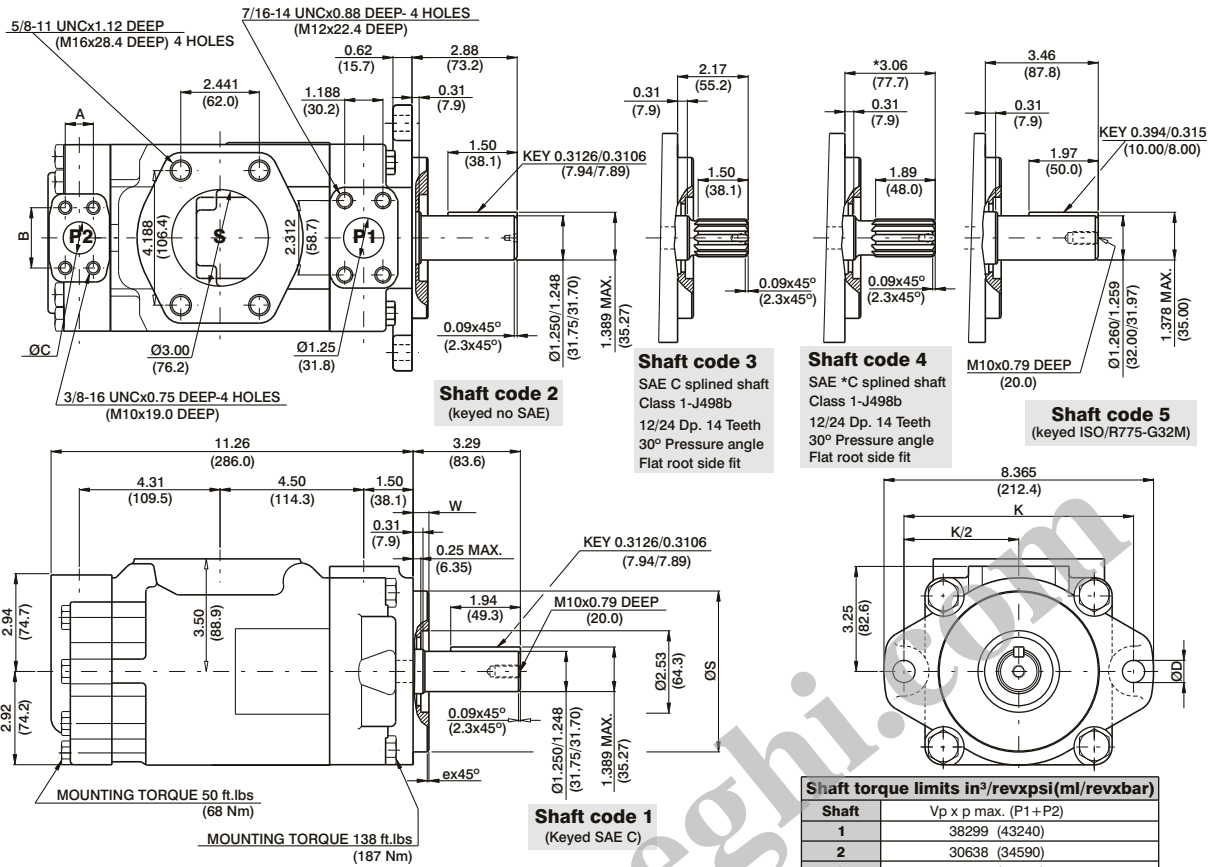

**Alternate mounting flange**

Series	ØS		ex45°	W	K	ØD
	MAX.	Min.				
VT7DB	4.921 (124.99)	4.919 (124.94)	0.079 (2.0)	0.374 (9.49)	7.087 (180.0)	0.709 (18.0)
VT7DBS	5.00 (127.00)	4.998 (126.94)	0.051 (1.3)	0.50 (12.7)	7.126 (181.0)	0.689 (17.5)

**Shaft torque limits in<sup>3</sup>/revxpsi(ml/revxbar)**

Shaft	Vp x p max. (P1+P2)
1	38299 (43240)
2	30638 (34590)
3	54207 (61200)
4	54207 (61200)
5	37644 (42542)

**Alternate connect.variables**

	00 & M0	01 & M1
A	1.031 (26.2)	0.874 (22.2)
B	2.06 (52.4)	1.874 (47.6)
C	1.00 (25.4)	0.75 (19.05)

## OPERATING CHARACTERISTICS - TYPICAL (24 cST) (Input power p (KW) for one cartridge only)

Pressure port	Series	Volumetric Displacement Vp		Flow q & n = 1800 rpm						Input power p & n = 1800 rpm					
		in <sup>3</sup> /rev	cm <sup>3</sup> /rev	p = 0 bar (0 psi)		p = 140 bar (2000 psi)		p = 250 bar (3630 psi)		p = 7 bar (100 psi)		p = 140 bar (2000 psi)		p = 250 bar (3630 psi)	
				gpm	lpm	gpm	lpm	gpm	lpm	hp	kw	hp	kw	hp	kw
P1	B14	2.68	43.9	20.92	79.1	19.18	72.5	17.81	67.3	3.46	2.6	27.77	20.7	47.03	35.0
	B17	3.36	55.0	26.16	98.8	24.41	92.3	23.04	87.0	3.77	2.8	33.88	25.3	57.71	43.0
	B20	4.03	66.0	31.39	118.6	29.64	112.0	28.27	106.8	4.07	3.0	39.98	29.8	68.39	50.9
	B22	4.29	70.3	33.43	126.4	31.69	119.8	30.32	104.6	4.19	3.1	42.37	31.6	72.57	54.0
	B24	4.95	81.1	38.57	145.8	36.82	139.2	35.45	134.0	4.49	3.4	48.36	36.1	83.06	61.9
	B28	5.49	89.9	42.80	161.8	41.06	155.2	39.69	150.0	4.74	3.5	53.30	39.7	91.70	68.3
	B31	6.05	99.1	47.18	178.3	45.43	171.7	44.06	166.5	4.99	3.7	58.41	43.6	100.63	75.0
	B35 <sup>1)</sup>	6.92	113.4	53.93	203.9	52.18	197.2	50.81	192.0	5.39	4.0	66.29	49.4	114.42	85.3
	B38 <sup>1)</sup>	7.36	120.6	57.35	216.8	55.61	210.2	54.24	204.9	5.59	4.2	70.28	52.4	121.42	90.5
	B42 <sup>2)</sup>	8.39	137.5	65.39	247.2	63.65	240.6	62.28	235.4	6.05	4.5	79.66	59.4	137.83	102.7
045 <sup>3)</sup>	8.89	145.7	69.29	262.0	67.11	253.6	65.31	246.8	6.74	5.0	83.75	62.4	145.79	108.7	
050 <sup>4)</sup>	9.64	157.9	75.14	284.0	72.96	275.8	71.78	271.3	7.08	5.3	90.58	67.5	134.50	100.3	
P2	B02	0.35	5.7	2.76	10.4	2.33	8.8	1.80	6.8	0.74	0.55	4.02	2.99	8.10	6.04
	B03	0.60	9.8	4.66	17.6	4.23	15.9	3.70	14.0	0.85	0.63	6.24	4.65	12.93	9.64
	B04	0.78	12.8	6.09	23.0	5.66	21.4	5.13	19.4	0.94	0.70	7.90	5.89	16.55	12.34
	B05	0.97	15.9	7.56	28.6	7.13	26.9	6.60	25.0	1.02	0.76	9.62	7.17	20.29	15.13
	B06	1.21	19.8	9.42	35.6	8.99	33.9	8.46	32.0	1.13	0.84	11.79	8.79	25.00	18.64
	B07	1.37	22.5	10.70	40.4	10.27	38.8	9.74	36.8	1.20	0.89	13.29	9.91	28.26	21.07
	B08	1.52	24.9	11.84	44.7	11.41	43.1	10.88	41.1	1.27	0.95	14.62	10.90	31.15	23.23
	B09	1.71	28.0	13.31	50.3	12.87	48.6	12.35	47.0	1.36	1.01	16.35	12.19	34.92	26.04
	B10	1.94	31.8	15.12	57.2	14.69	55.5	14.16	53.5	1.46	1.09	18.45	13.75	39.48	29.44
	B11 <sup>5)</sup>	2.13	34.9	16.64	62.9	16.19	61.2	15.68	59.3	1.55	1.16	20.17	15.04	43.22	32.23
	B12 <sup>5)</sup>	2.50	40.9	19.50	73.7	19.07	72.1	18.54	70.1	1.72	1.28	23.55	17.56	50.58	37.71
	B14 <sup>5)</sup>	2.75	45.1	21.40	80.8	20.95	79.2	20.44	77.0	1.83	1.36	25.80	19.24	55.48	41.37
	B15 <sup>5)</sup>	3.05	50.0	23.78	89.8	23.35	88.3	22.88	86.5	1.97	1.47	28.55	21.28	57.35	42.76

1) B35-B38 = 280 bar (4060 psi) max.int. 2) B42 = 260 bar (3770 psi) max.int. 3) 045 = 240 bar (3500 psi) max.int. 4) 050 = 210 bar (3000 psi) max.int.  
5) B11-B12-B14 = 300 bar (4350 psi) & B15 = 280 bar (4060 psi) max.int. And Max. Speed = 3000 rpm